

Typical Features

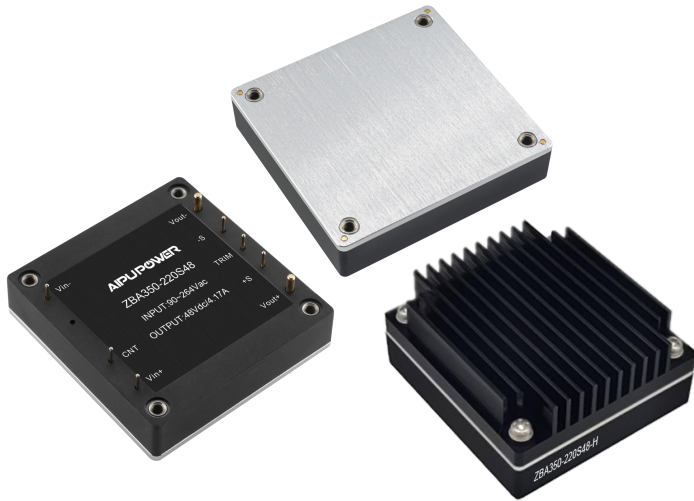

- ◆ Wide input voltage range 3:1
- ◆ Efficiency 85%(Typ.)
- ◆ Low standby power consumption
- ◆ Operating Temperature from -40°C to +105°C
- ◆ Isolation voltage 2500Vac(input-output) & 2100Vac(input-case)
- ◆ Input under-voltage protection, output OVP, SCP, OCP, OTP
- ◆ Standard 1/2 brick size

The **ZBA350-220S48 series** consists of high-performance half-brick AC-DC power modules featuring a 220VAC rated input (90-264VAC range) and a regulated single 48V/200W output with no minimum load requirement. Providing high isolation and operating temperatures up to 105°C, the series includes comprehensive protections against input undervoltage, input overvoltage, output overcurrent, overvoltage, overtemperature, and short circuits, plus Remote Sense and output voltage trimming.

Selection Guide							
Part No.	Input voltage range (VAC)	Output Power (W)	Output Voltage (VDC)	Output Current (A)	Ripple & Noise (mVp-p)	Full load Efficiency (%) Min/Typ.	Remark
ZBA350-220S48	90-264	200	48	4.17	480	83/85	Positive logic Standard
ZBA350-220S48-H							Positive logic With heat sink

Input Specifications						
Item	Operating conditions	Min.	Typ.	Max.	Unit	
Input current Max	Input 85VAC, full load	--	--	3	A	
Input surge current Max	Input 220Vac, NTC(5.6R/Ø20mm) connected in series	--	--	20	A	
Standby power consumption	Rated input voltage	--	--	2	W	
Start-up voltage		--	--	90	VAC	
Input surge voltage (1S max.)	Exceeding this range may cause permanent damage.	--	--	315		
Input under-voltage protection	No load	--	--	88		
Input voltage frequency		47	--	63	Hz	
PF value	220Vac input, full load output	95%	--	--	%	

Output Specifications						
Item	Working conditions	Min.	Typ.	Max.	Unit	
Output Voltage Accuracy	Rated input voltage, 10% load	--	±0.5	±1.0	%	
Line Regulation	Full load, input voltage from low to high	--	±0.1	±0.2		
Load Regulation	Rated input voltage, 10%-100% load	--	±0.2	±0.5		
Transient recovery time	25% load step change (step rate 1A/50uS)	--	200	250	uS	
Transient Response Deviation		-5	--	+5	%	
Temperature Drift Coefficient	Full load	-0.02	--	+0.02	%/°C	

Ripple & Noise	20M bandwidth, test with $\geq 220\mu\text{F}$ capacitor	--	240	480	mVp-p
Output voltage trim (TRIM)		-20	--	+10	%
Remote Sense (Sense)		--	--	5	%
Over temp protection(OTP)	Temperature of the metal base surface	105	115	125	$^{\circ}\text{C}$
Output over voltage protection(OVP)		125	--	140	%
Output over current protection(OCP)		4.5	--	5.8	A
Output short circuit protection(SCP)		Hiccup, continuous, self-recovery			

General Specifications

Item	Operating conditions		Min.	Typ.	Max.	Unit
Isolation Voltage	I/P-O/P	Test 1min, leakage current < 3mA	2500	--	--	VAC
	I/P-Case	Test 1min, leakage current < 3mA	2100	--	--	VAC
	O/P-Case	Test 1min, leakage current < 3mA	500	--	--	VDC
Insulation resistance	I/P-O/P	@ 500VDC	100	--	--	M Ω
Switching frequency			--	280	--	KHz
MTBF	MIL-HDBK-217F@25 $^{\circ}\text{C}$		150	--	--	K hours

Environmental Specifications

Item	Operating conditions	Min.	Typ.	Max.	Unit
Operating Temperature	Refer to the temperature derating curve	-40	--	+105	$^{\circ}\text{C}$
Storage Humidity	No condensing	5	--	95	%RH
Storage Temperature		-40	--	+125	$^{\circ}\text{C}$
Pin Soldering temperature	1.5mm from the case, < 1.5S	--	--	+350	
Cooling requirements		EN60068-2-1			
Dry and heat requirements		EN60068-2-2			
Moisture and heat requirements		EN60068-2-30			
Shock and vibration		IEC/EN 61373, Category 1, Class B			

EMC Specifications

EMI	CE	EN50121-3-2	150kHz-500kHz 79dBuV	
		EN55016-2-1	500kHz-30MHz 73dBuV	
	RE	EN50121-3-2	30MHz-230MHz 40dBuV/m at 10m	
		EN55016-2-1	230MHz-1GHz 47dBuV/m at 10m	
EMS	ESD	IEC/EN61000-4-2/GB/T 17626.2-2006	Contact $\pm 6\text{KV}$ /Air $\pm 8\text{KV}$	Perf. Criteria A
	RS	IEC/EN61000-4-3/GB/T 17626.3-2006	10V/m	Perf. Criteria A
	EFT	IEC/EN61000-4-4/GB/T 17626.4-2008	$\pm 2\text{kV}$ 5/50ns 5kHz	Perf. Criteria A
	Surge	IEC/EN61000-4-5/GB/T 17626.5-2008	line to line $\pm 1\text{KV}$ (42 Ω , 0.5 μF)	Perf. Criteria A
	CS	IEC/EN61000-4-6/GB/T 17626.6-2008	0.15MHz-80MHz 10 V r.m.s	Perf. Criteria A

Physical Specifications

Case Materials	Metal base + Plastic case in black with flame class UL94 V-0
Heat sink	Dimension 61.0x57.9x15.0mm, weight 72g, Aluminium, anodized black
Cooling method	Conduction cooling or forced fan cooling
Weight	Standard 125g, with heatsink 203g

Mechanical Dimensions and Pin-Out description

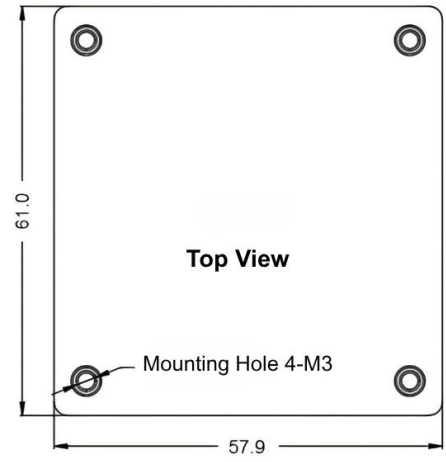
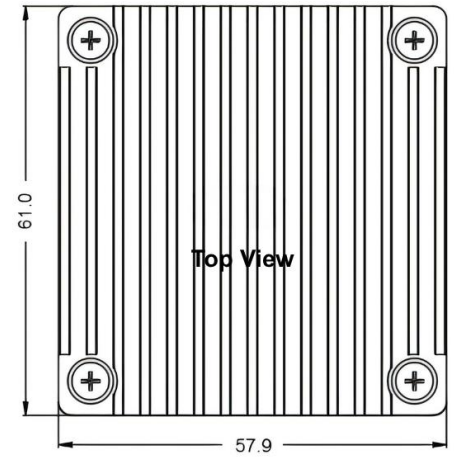
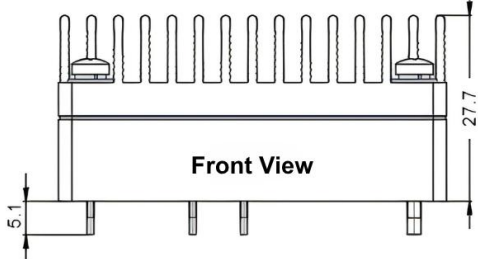
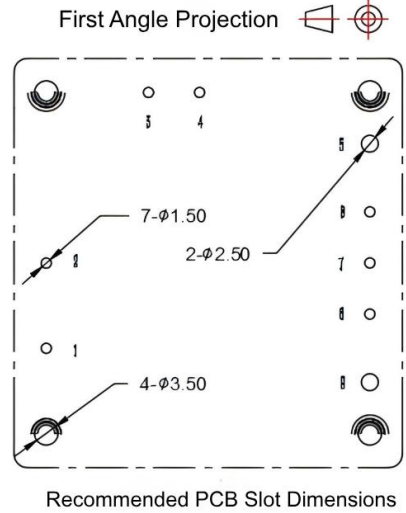
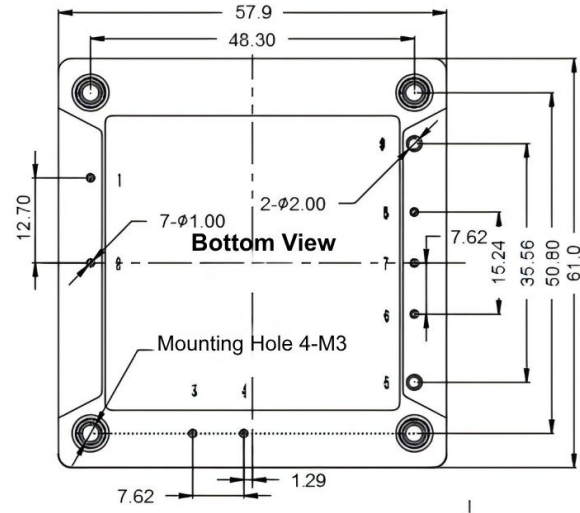

Standard + Heat sink
61.0*57.9*27.7mm

Standard
61.0*57.9*12.7mm

- Note:**
- Unit: mm
 - Pin 1, 2, 3, 4, 6, 7, 8 diameter: 1.00mm
 - Pin 5, 9 diameter: 2.00mm
 - Tolerance: X.X ±0.50 mm, X.XX ±0.10 mm
 - Mounting Torque: 0.4 N·m (Max.)

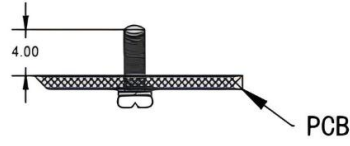

No.	1	2	3	4	5	6	7	8	9
Pin-out	AC1	AC2	BC+	BC-	Vout+	+S	TRIM	-S	Vout-
Description	AC Input 1	AC Input 2	PFC Cap. Positive	PFC Cap. Negative	Positive Output	Remote Sense Positive	Output Trim	Remote Sense Negative	Negative Output

Product Performance Curves

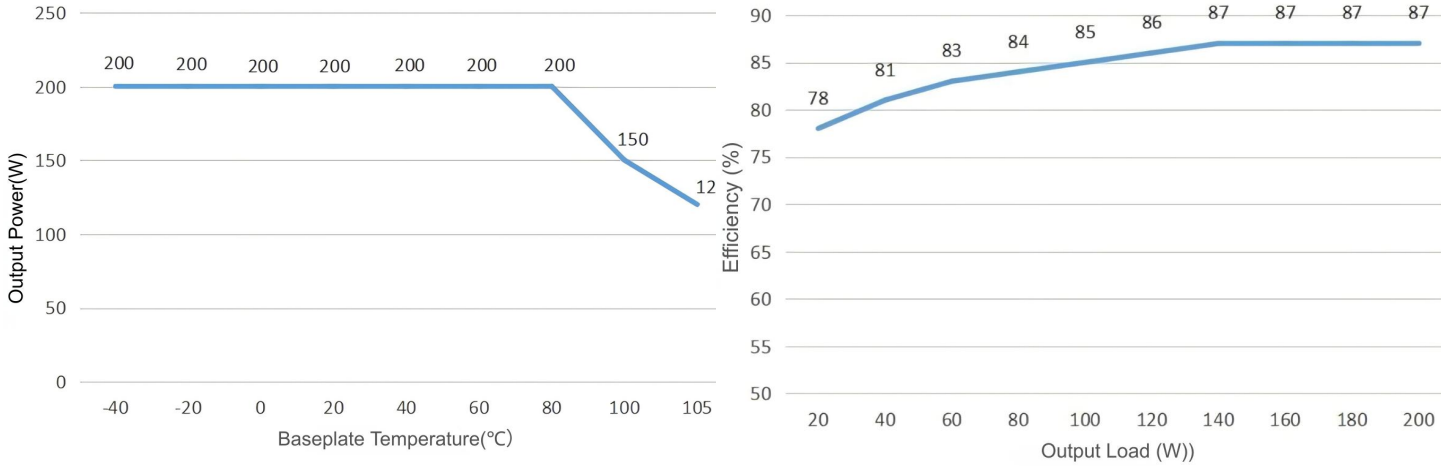

- Notes:
- Both temperature derating and efficiency curves are based on typical values.
 - Derating curves are measured under our laboratory conditions. If the actual application environment differs, ensure the case temperature does not exceed 100°C. The module can be used at any load within its rated range provided this temperature limit is maintained.

Recommended Circuits for Application

1. Ripple & Noise

All the products will be tested according to this circuit shown below before shipping.

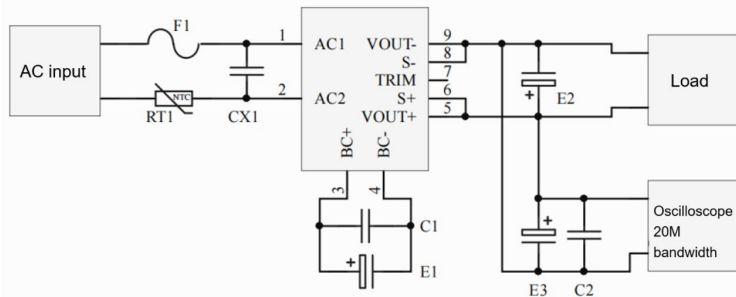

Vo	E1 (uF)	E2 (uF)	C1 (uF)	C2 (uF)	E3 (uF)
3.3VDC	100uF	1000uF	1uF/520V	1uF	10uF
5VDC		680uF	1uF/520V		
12VDC		470uF	1uF/520V		
.....		220uF	1uF/520V		
48VDC		220uF	1uF/520V		
.....		68uF	1uF/520V		
110VDC		68uF	1uF/520V		

2. Recommended circuit for application

If this recommended circuit is not adopted, C3X should be $\geq 0.47\mu\text{F}$, E1 should be $\geq 100\mu\text{F}$, NTC must be connected, C1 should be $\geq 1\mu\text{F}$ at the temperature $\leq -25^\circ\text{C}$. The power supply could be failed if these conditions are not met.

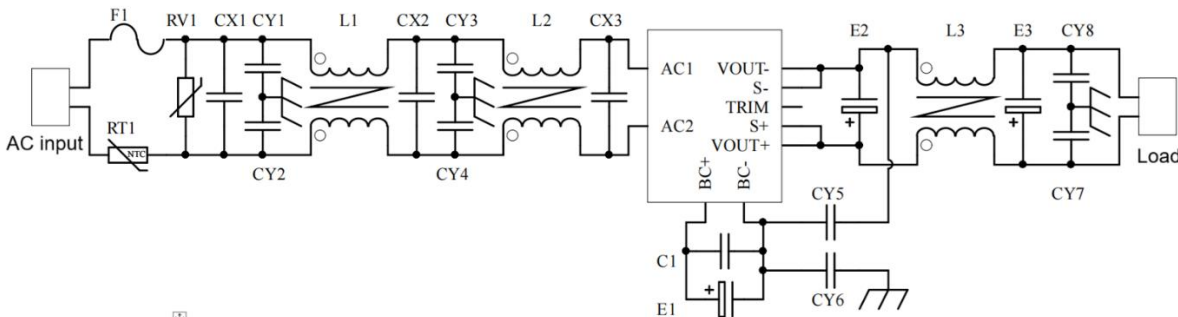

F1	T6.3A/250V FUSE
RV1	10D 620V TVS
RT1	5.6Ω/∅20mm NTC
CX1, CX2, CX3	224/250VAC/X2 Capacitor
CY1, CY2, CY3, CY4, CY6	102/250Vac/Y2 Capacitor
CY7, CY8	103/2KV Ceramic Capacitor

CY5	471/250Vac/Y1 Capacitor
C1	105/630V Polyester Film Capacitor
E1	220μF/450V Electrolytic capacitor
E2, E3	220μF/63V Low ESR capacitor
L1, L2	>8mH, the temperature rise <25°C@3A
L3	>470 μH, the temperature rise <25°C@4.5A

3. Remote Sense: Usage & Precautions

1) Without Remote Sense

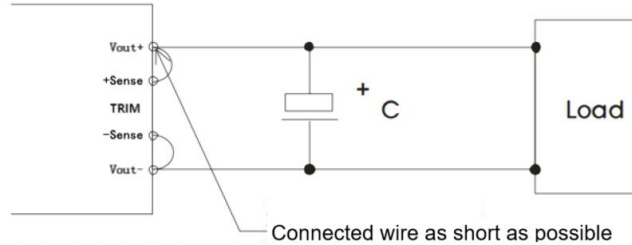

Precautions:

1. If the remote sense function is not used, ensure +S is shorted to +Vout and -S is shorted to -Vout.
2. The connections between +Vout / +S and -Vout / -S must be as short as possible and placed close to the pins; otherwise, the module's stability may be compromised.

2) With Remote Sense

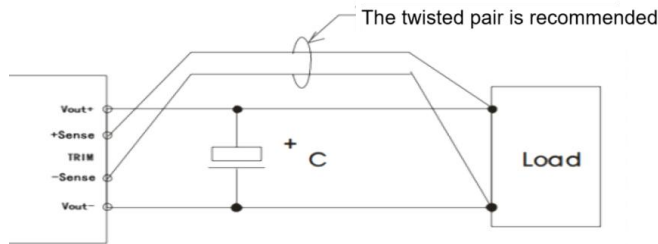

Precautions:

1. With remote sense, excessively long sense leads may cause output voltage instability.
2. With remote sense, use shielded twisted pair wires and keep them as short as possible.
3. Use wide PCB traces or heavy-gauge wires between the module and the load. Ensure the total voltage drop is below 0.3V to maintain the output voltage within specified limits.
4. Lead impedance may cause output voltage oscillation or increased ripple; please verify performance prior to use.

4. TRIM & TRIM resistance calculation

Output Voltage Trim Range vs. Resistor Value:

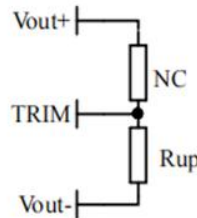

Voltage-up: Add Rup between Trim and Vout-

$$R_{up} = 140 / (\Delta U - 5.1) \text{ (K}\Omega\text{)}$$

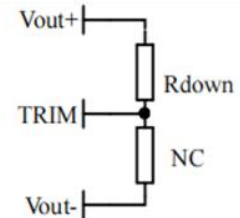

Voltage-down: Add Rdown between Trim and Vout+

$$R_{down} = 56 * (48 - 2.5 - \Delta U) / (\Delta U - 5.1) \text{ (K}\Omega\text{)}$$

5. Direct parallel connection for higher power is not supported. For parallel applications, please contact our technical support team.

Others

1. This product is covered by a two-year warranty. Any failure or damage that occurs under normal use will be repaired free of charge. In the event of damage caused by improper use, incorrect application, or manufacturing process errors not attributable to our product, paid repair services can be provided.
2. AIPUPOWER offers custom product design services as well as matching filter modules. For details, please contact our technical support team directly.
3. Updated: April 16, 2026

Guangzhou Aipu Electron Technology Co., Ltd

Address: Building 4, HEDY Park, No.63, Punan Road, Huangpu Dist, Guangzhou, China.

Tel: 86-20-84206763 Fax: 86-20-84206762 HOTLINE: 400-889-8821

E-mail: sales@aipu-elec.com Website: <https://www.aipupower.com>